

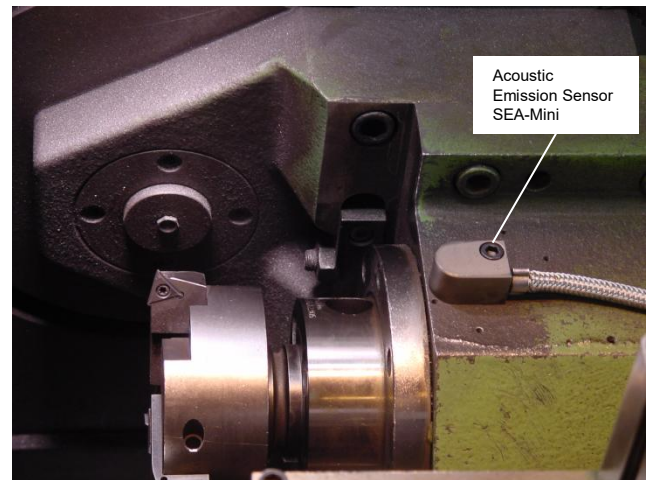

Acoustic Emission Sensor

SEA and SEA-Mini

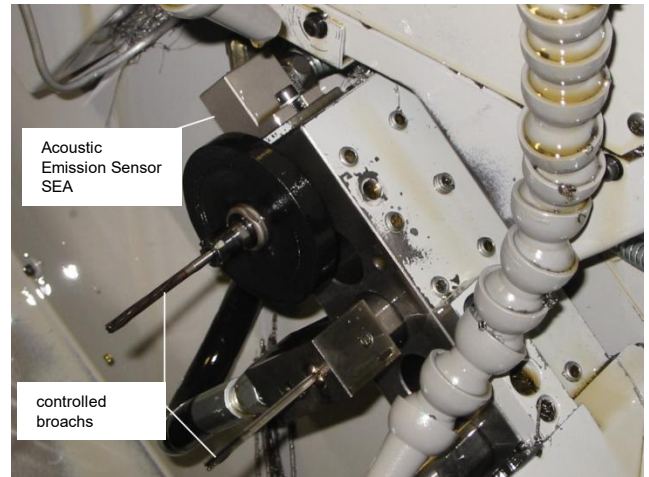

Technical data:

| | |
|---------------------|---|
| Frequency range: | 5 kHz – 1 MHz |
| Amplitude dynamics: | 110 dB (= difference between greatest and smallest measurable acoustic emission amplitude) |
| Temperature range: | -40 °C to +85 °C |
| Power supply: | via acoustic emission processor SEP (± 15V) |
| Cable: | coax cable RG174U standard cable length: 3m |

Function:

- Measurement of acoustic emissions of tools during turning, drilling, milling and grinding operations.
- Acoustic detection of contact between grinding disk and workpiece for gap control
- Gap elimination drill/workpiece
- Acoustic workpiece dimension control based on detection of friction noise between a test blade and the workpiece

Installation:

The sensor **SEA** or **SEA-Mini** is screwed on with a metal cap as close as possible to the tool to be monitored or the workpiece to be machined. Before installation, the mounting surface must be cleaned to bare metal. Apply the provided coupling grease to the center of the base plate to avoid an air gap between sensor and mounting surface and thus ensure proper coupling of the sensor.

When installed in tight spaces or on cylindrical spindle bearings, the sensor **SEA** or **SEA-Mini** may also be mounted without the metal cap. In this case, it must be pressed on using an appropriate clamp screw, flat spring or tube clamp with a maximum force of 50 N (approx. 5 kg) on the tip at its head. On curved surfaces, at least the center of the white base plate must be in contact with the mounting surface.

When measuring on the machine table, make sure to clean the contact surfaces of workpiece and clamping devices in order to achieve an optimum of large-area low-loss contact between the machine parts. Liquids such as cutting oil or emulsion will improve the acoustic emission transmission across the gaps between these machine parts.

Sensor SEA:

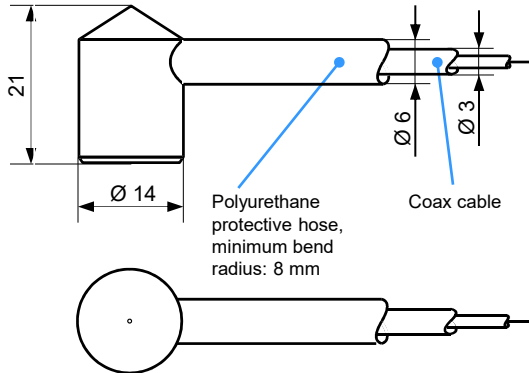

Mounting cap SEA:

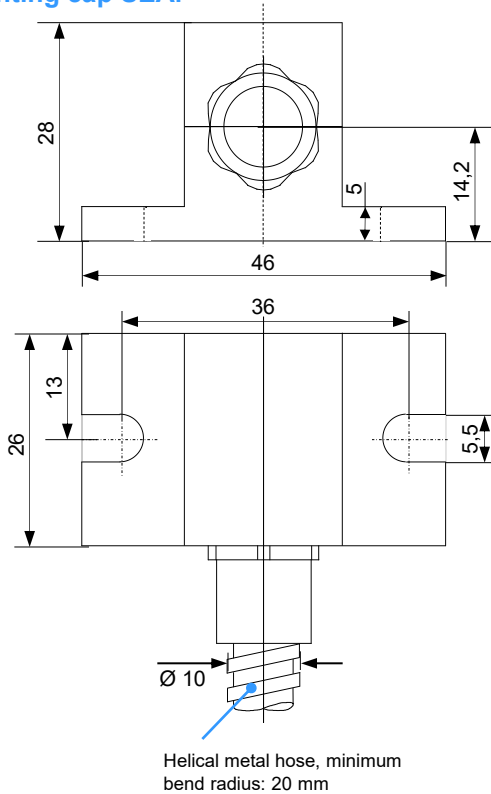

Sensor SEA-Mini:

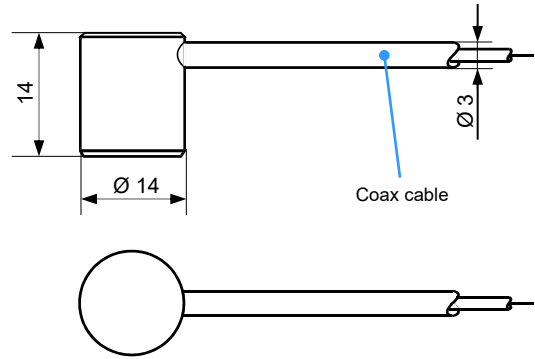

Mounting cap SEA-Mini:

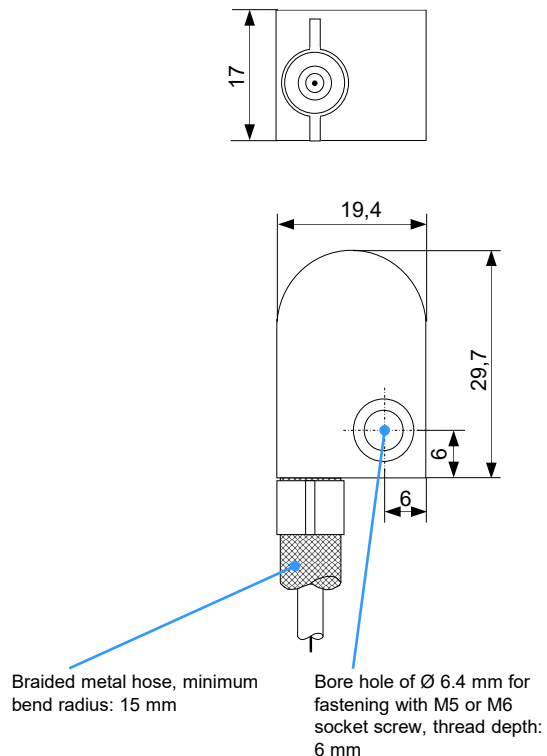

Order number:

| | |
|---------|-------------|
| 6.2.1 | SEA MF |
| 6.2.1NF | SEA NF |
| 6.2.2 | SEA-Mini MF |
| 6.2.2NF | SEA-Mini NF |

Measuring principle:

Piezoelectric measurement of acoustic emissions transmitted from tools to the sensor and generating from machining operations and from tool breakage. The sensor contains an impedance transformer for disturbance-free transmission of the measured value to the acoustic emission processor SEP via coaxial cable.