



Effective Power Module WLM-3S



Technical data

Voltage and current consumption
WLM-3S without sensors:

+15 V: 50 mA
-15 V: 50 mA

Voltage and current consumption
per current sensor:

+/- 15 V: 10 mA (through WLM-3S)

Temperature range:

+5 °C to +70 °C

Sensitivity:

See 'Current sensor table'

Cable (WLM-3S to tool monitor):

4 x 0.25 mm² + shield (LiYCY)
Length: max. 100 m
(Not included)

Cable (current sensor to WLM-3S):

4 x 0.25 mm² + shield (LiYCY)
2 m included
(Other lengths available on request)

Housing

Makrolon 8020, UL94V-1

For installation in electrical cabinet,
either using 2 x M4 bolts or
on standard rail TH35 (DIN EN 60715)

- Optimised board layout using low-noise components
- Measurement sensitivity switchable between factors 3 and 9 via external control signal
- Highly sensitive and fast-responding
- LED for current overload indication
- Effective power measurement for drive motors and axis motors, including at very low speeds down to stationary
- DIN rail or bolt mounting

Special capabilities

The WLM-3S is an effective power meter with enhanced sensitivity for monitoring very small tool and chip sections

Setting up/Operation



Trimmer to adjust smoothing

If monitoring is difficult owing to 'noisy' measurement curves, the level of smoothing should be increased in the SEM-Modul Tool Monitor (Edit menu > Measurement point > Smoothing time').

In exceptional circumstances the measured value can be smoothed directly on the WLM-3V under 'Smoothing'. Maximum smoothing is achieved after approximately 20 turns (clockwise). The adjustment range is between 3.3 ms (factory preset, extreme left) and 663 ms when rotated fully to the right. (If turned too far to the left or right, the end of the adjustment range is indicated by a gentle tick.)



Jumper JP4 for adding a low-pass filter (fg = 8 Hz)

ON (2-3) = 8Hz low-pass (factory setting)
OFF (1-2) = No low-pass filtering

The WLM-3S is equipped with a low-pass filter, which as delivered is switched in (jumper position = ON). If particularly fast or short-term changes in power are to be measured, however, the low-pass filter should be switched out (jumper position = OFF).

Example of use:

- Rapid gap elimination e.g. in grinding
- Waviness evaluation for break out detection in the cutter head or hob cutter.



Input (terminal 16) for amplification of measured value

Measurement value amplification (switch input):
When the voltage on the switch is +24V (14 - 38V AC/DC) the measurement value amplification (gain) is 9.

Connection diagram

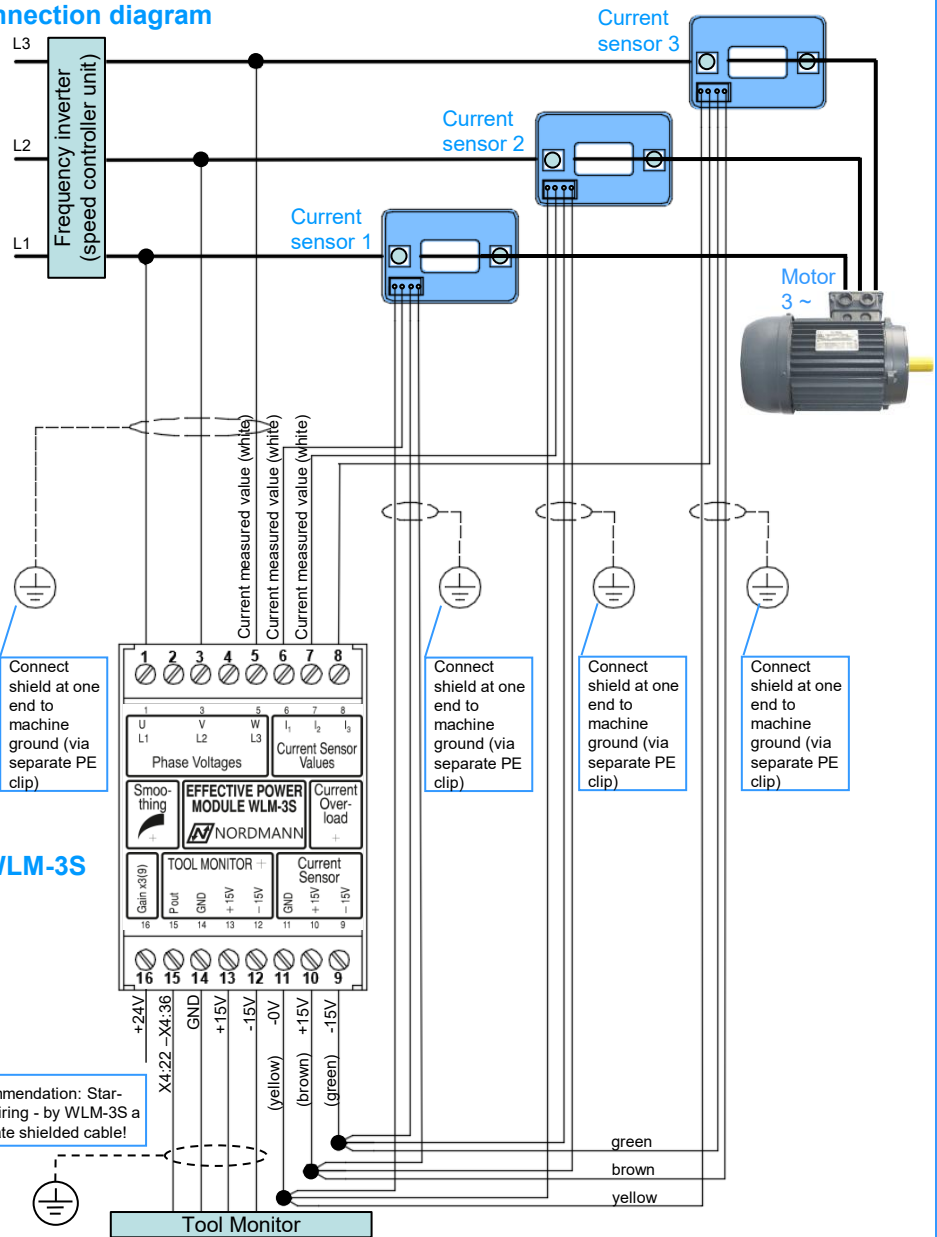

WLM-3S

Recommendation: Star-type wiring - by WLM-3S a separate shielded cable!

Jumper table

for amplification of measured value

	JP1, JP2 and JP3 inserted (factory setting)	JP1, JP2 and JP3 removed
No control voltage on terminal 16 (factory setting)	V = 1	V = 3
Control voltage on terminal 16	V = 9	V = 9

Jumpers JP1, JP2 and JP3 for measured value amplification

Jumpers JP1, JP2, JP3 (see 'Circuit board') can be moved to set the amplification to unity or factor 3. Removing the jumpers raises the gain by a factor of 3 (see 'Jumper table'). As factory preset, the jumpers are inserted (i.e. gain = 1).

Note: Removing the jumpers (and thus increasing the amplification) will also amplify the inherent noise of the current sensors. The following alternatives would therefore be preferable wherever possible in order to obtain higher measured values:

- Increase number of conductor windings through the current sensor
- Replace the current sensors with more sensitive types.

Circuit board

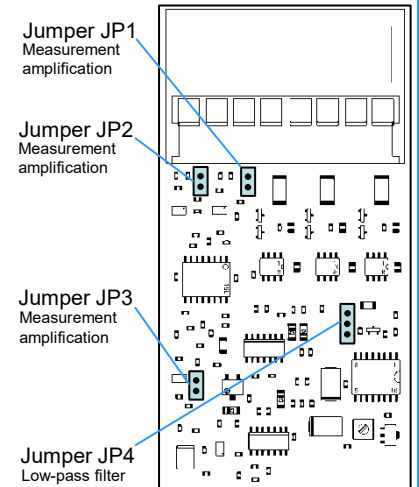

Current sensor

Dimension of opening:

The current sensors (hall sensors) are available with different opening dimensions (types 1 and 2, see Current sensor table), so that even larger cable lugs and conductor sections can normally be threaded through or wound. Type 3 current sensors can be hinged open.

Selecting the correct current sensor:

In general, a current sensor is used whose power (kW rating, see Current sensor table) roughly matches the nominal power of the motor being monitored. If, say, only small tools are in use, yet with relatively powerful drive motors, it can be advantageous to select a more sensitive current sensor type. It is important to ensure in any case that the sensor is not overdriven.

The WLM-3S features a 'Current Overload' LED to indicate any such overloading of the sensor. The LED is illuminated **red** when the measured current value overloads the sensor (corresponding to a voltage > 10 V). (Note: it is not uncommon for an overload to occur while the spindle is accelerating, but this is not critical since tools are not normally monitored during the acceleration phase.)

If the LED does **not** light up at all, the measured current value is too low (corresponds to a voltage < 1 V). If the measurement curves obtained are really considered 'unusable', the number of conductor windings should be increased or the next 'smaller' sensor type used. When the LED lights up **green**, the measured current value is in the optimum range (corresponding to a voltage > 1 V to 10 V).

Measurement

The WLM-3S effective power module features a **linear** measured value output (terminal 12) with output voltages from -15 V to +15 V. The positive range indicates motor operation and the negative range indicates generator operation. The SEM-Modul Tool Monitor evaluates only motor operation, however (0 V to +10 V). On the other hand, the SEM-Modul Tool Monitor-e evaluates input voltages between -10 V and +10 V, thus both motor and generator modes.

Taring onto no-load power

Should unwanted differences in the level on the measurement curve occur, e.g. because of an increased motor temperature, it is advisable to tare the unit to the no-load power. This is done by software using the 'digital zero adjustment' function in the Tool Monitor. This function allows an adjustable time to be set, at the end of which the measurement curve is reduced or raised constantly to zero or to a fixed (offset) value. It is important to ensure that the moment of zero adjustment is set to occur **after** an acceleration phase of the spindle and immediately **before** contact between the tool and work piece.

Current sensors

Type 1



Conductor opening:
20.4 mm x 10.4 mm
Available kW rating:
8 kW

Type 2



Conductor opening:
20.5 mm x 15.0 mm
Available kW rating:
8 kW, 16 kW, 32 kW,
64 kW, 96 kW

Type 3

(hinged)



Conductor opening: Ø
21.0 mm
Available kW rating:
8 kW, 16 kW, 32 kW,
64 kW, 80 kW

Conversion formulae

(power and torque)

The **measured power value** can be used to make an exact quantitative determination of the effective power. This applies, however, only if the internal jumpers JP1, JP2 and JP3 are inserted and there is no control voltage on terminal 16, so that the amplification factor (gain) is 1.

The (standard) effective power scales of the Tool Monitor indicate the unit [kW]. The scaling is adjustable, however, so that another display of [Nm] or [N] can be obtained following the appropriate conversion.

Power measurement when using three current sensors per phase of a three-phase motor:

$$P = \frac{63.9}{n \times S} \times V_{\text{Meas}} \quad [\text{W}]$$

Torque:

$$M = \frac{P}{2 \times \pi \times n_s} \quad [\text{Nm}]$$

Feed force:

$$F_f = \frac{P}{v_f} \quad [\text{N}]$$

V_{Meas} : Voltage on measured value output (terminal 12) [V]

π : 3.14 (pi)

n : Number of conductor windings through sensor opening

n_s : Tool spindle speed [1/s] or [Hz]

S : Current sensor sensitivity [V/A]

P : Effective power [W]

M : Torque [Nm]

F_f : Feed force [N]

v_f : Feed speed [m/s]

Current sensor table

Order no.	Type	kW rating [kW]	Conductor opening [mm]	Measurement range [V]	Sensitivity S [V/A]	Resultant sensitivity of WLM-3S [V/kW] for the different amplification factors (see Jumper table)		
						V = 1	V = 3	V = 9
7.1.8	1	8	20.4 mm x 10.4 mm	± 12 V	0.08 V/A	1.252 V/kW	3.757 V/kW	11.267 V/kW
7.2.8	2		20.5 mm x 15.0 mm					
7.3.8	3		Ø 21.0 mm (hinged)					
7.2.16	2	16	20.5 mm x 15.0 mm	± 12 V	0.04 V/A	0.626 V/kW	1.879 V/kW	5.634 V/kW
7.3.16	3		Ø 21.0 mm (hinged)					
7.2.32	2	32	20.5 mm x 15.0 mm	± 12 V	0.02 V/A	0.313 V/kW	0.9393 V/kW	2.817 V/kW
7.3.32	3		Ø 21.0 mm (hinged)					
7.2.64	2	64	20.5 mm x 15.0 mm	± 12 V	0.01 V/A	0.1565 V/kW	0.4696 V/kW	1.4083 V/kW
7.3.64	3		Ø 21.0 mm (hinged)					
7.3.80	3	80	Ø 21.0 mm (hinged)	± 12 V	0.008 V/A	0.1252 V/kW	0.3757 V/kW	0.11267 V/kW
7.2.96	2	96	20.5 mm x 15.0 mm	± 12 V	0.00667 V/A	0.1043 V/kW	0.3131 V/kW	0.9389 V/kW

WLM-3S

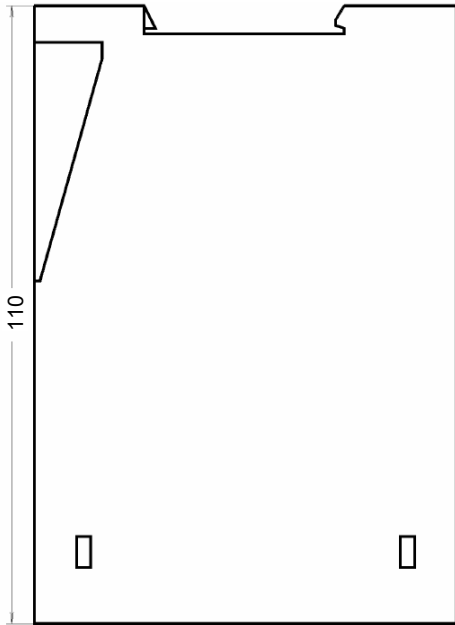
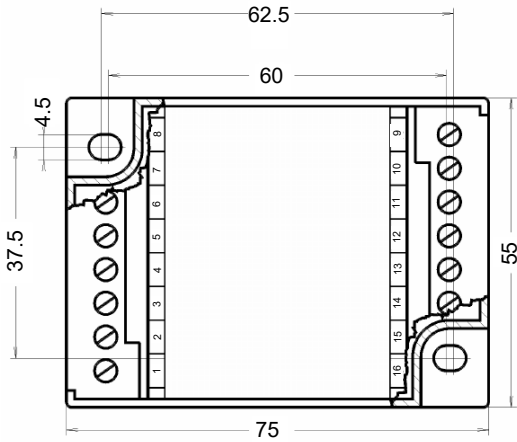

Current sensor type 1

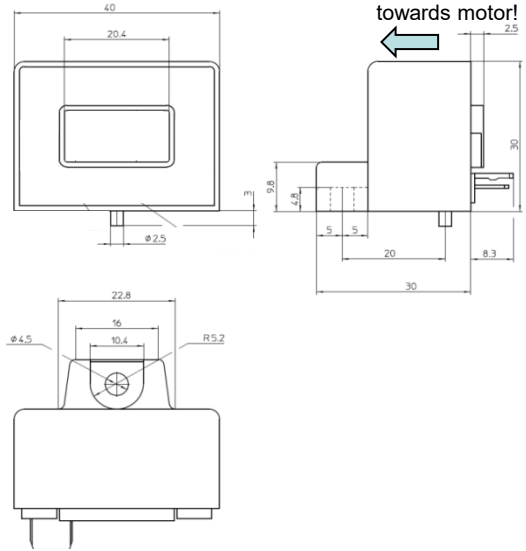

Current sensor type 2

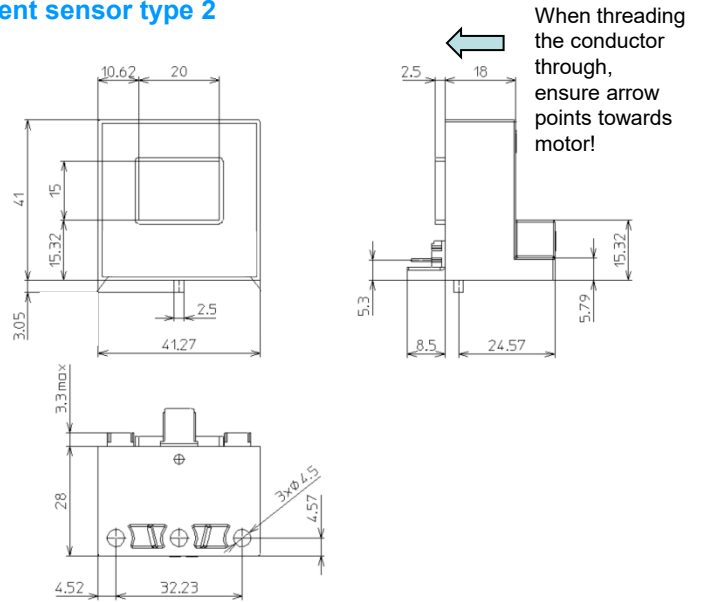

Current sensor type 3

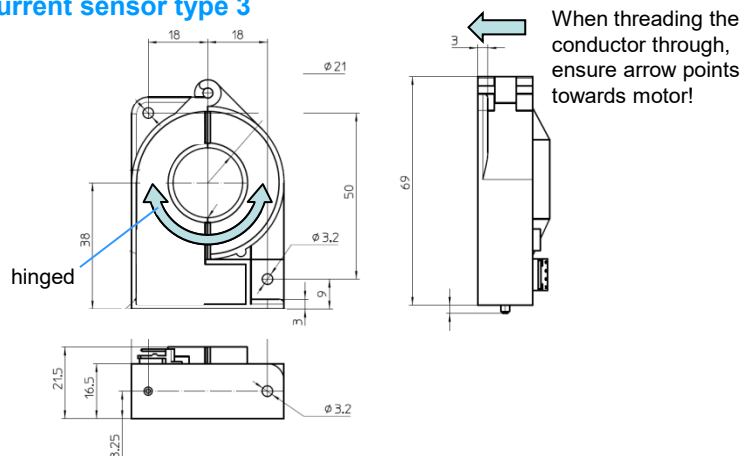

Designation:

Order no.:

WLM-3S	7.3.2.S
Current sensor (type 1 / 8 kW)	7.1.8
Current sensor (type 2 / 8 kW)	7.2.8
Current sensor (type 3 / 8 kW)	7.3.8
Current sensor (type 2 / 16 kW)	7.2.16
Current sensor (type 3 / 16 kW)	7.3.16
Current sensor (type 2 / 32 kW)	7.2.32
Current sensor (type 3 / 32 kW)	7.3.32
Current sensor (type 2 / 64 kW)	7.2.64
Current sensor (type 3 / 64 kW)	7.3.64
Current sensor (type 3 / 80 kW)	7.3.80
Current sensor (type 2 / 96 kW)	7.2.96